

# Field Test Plan for TDD-LTE/LTE-A synchronization in systems using Assisted Partial Timing Support and Partial Timing Support



---

The current standards and profiles for frequency and phase synchronization using Precision Time Protocol (PTP) refer to networks in which every element is aware of PTP, allowing the error induced by intermediate nodes to be mitigated or recorded. There is a requirement to consider networks that have elements that are not PTP aware and new standards and profiles are emerging to define Assisted Partial Timing Support (APTS) and Partial Timing Support (PTS).

This document provides test procedures to ensure high quality phase/frequency for TDD-LTE/LTE-A networks running PTP protocol for timing synchronization. In the event of non-compliance, possible causes of failure, impact on the network, and suggested remedial actions are included to help field engineers understand and troubleshoot network issues more efficiently.

# Contents

<b>1</b>	<b>Background</b>	<b>3</b>
<b>2</b>	<b>Test Setup</b>	<b>4</b>
2.1	ITU-T G.8271.2 Assisted Partial Timing Support	4
2.2	ITU-T G.8271.2 Partial Timing Support	4
<b>3</b>	<b>Sentinel Configuration</b>	<b>5</b>
3.1	1PPS Output	5
3.2	PTP Connections	5
3.3	Configuring Sentinel Operating Mode	5
3.4	Time Base Settings	6
3.5	Measurement Settings	7
3.6	PTP Mode	7
3.7	Signal Check	9
3.8	Start the Test	9
<b>4</b>	<b>Measurement Results Display</b>	<b>10</b>
<b>5</b>	<b>Test Cases</b>	<b>12</b>
5.1	1PPS Time Error Result in CAT	12
5.2	Generating pktSelected2WayTE Results using CAT	12
5.3	Measurements	13
<b>Appendix A: PTP Synchronization Technology</b>		<b>18</b>
<b>Appendix B: ITU-T G.8271.2 Network Reference Model and Limits</b>		<b>19</b>

---

**Note:** Measurement data shown in this document can also be imported to the Calnex Analysis Tool (CAT) for more detailed analysis. CAT is available for all Calnex Paragon and Sentinel products.



# 1 Background

The migration from 3G to FDD-LTE was seamless with regards to the backhaul network as only frequency synchronization to the base stations was required. TDD-LTE, on the other hand, requires precise phase synchronization to the base stations which necessitates the deployment of Precision Time Protocol (PTP)<sup>1</sup> and Global Navigation Satellite System (GNSS) receivers.

The performance of phase synchronization must be measured and monitored as non-compliance to standards will result in mobile service issues, including poor data transfer and re-transmissions, as well as dropped calls and failed handovers.

Initially, the standards and profiles for frequency and phase synchronization using PTP referred to networks in which every element was aware of PTP, however there is a requirement to consider networks that have elements that are not PTP-aware and new standards and profiles are emerging to define Assisted Partial Timing Support (APTS) and Partial Timing Support (PTS). One of these standards is ITU-T G.8271.2 which uses a percentage of the best case PTP packets to determine the network limits.

The following table describes the phase/time/frequency synchronization specifications for the packet mobile backhaul and the Air interface.

 **Note:** LTE-A technologies like MBSFN, CoMP and eICIC have similar demands for phase sync as shown in the table below. As such, the network limits mentioned above and this test plans apply to LTE-A as well.

Application	Frequency	Time	Packet Backhaul Spec
CDMA2000	±50 ppb	±3 to 10 µs	
TD-SCDMA	±50 ppb	±1.5 µs	
GSM	±50 ppb	n/a	±16 ppb (G.8261.1)
WCDMA	±50 ppb	n/a	±16 ppb (G.8261.1)
LTE (FDD)	±50 ppb	n/a	±16 ppb (G.8261.1)
LTE (TDD)	±50 ppb	±1.5 µs (< 3km cell radius) ±5 µs (< 3km cell radius)	±16 ppb (G.8261) ±1.1 µs (for ±1.5 µs G.8271.1)
LTE-A MBSFN	±50 ppb	±1 to 5 µs Implementation dependent	±16 ppb (G.8261.1) ±1.1 µs (for ±1.5 µs G.8271.1)
LTE-A CoMP	±50 ppb		
LTE-A eICIC	±50 ppb		
Small Cells	±100 ppb	n/a (FDD) ±1.5 µs (TDD) ±1 to 5 µs (eICIC)	±33 ppb ±1.1 µs (for ±1.5 µs G.8271.1)
Home Cells	±250 ppb	n/a (FDD) ±1.5 µs (TDD)	±100 ppb ±1.1 µs (for ±1.5 µs G.8271.1)

 **Note:** LTE-A mobile backhaul for example, the requirement is ±16 ppb for frequency stability as per G.8261.1 recommendation, and ±1.1 µs for phase stability as per G.8271.1 recommendation.

<sup>1</sup> See Appendix A

## 2 Test Setup

Typical field test setups using the Sentinel are shown below.

### 2.1 ITU-T G.8271.2 Assisted Partial Timing Support

In this case the packet network between the PRTC/GM and the eNodeB contains elements that are not PTP aware. The eNodeB can use GNSS as a preferred timing reference, relying on PTP as a backup for frequency when this is not available. Sentinel can be connected as a Pseudo PTP Slave or used in Monitor Mode, connecting between the PTP master and slave via an optical splitter or electrical TAP. It measures the performance of the network and the performance of the recovered clock simultaneously.

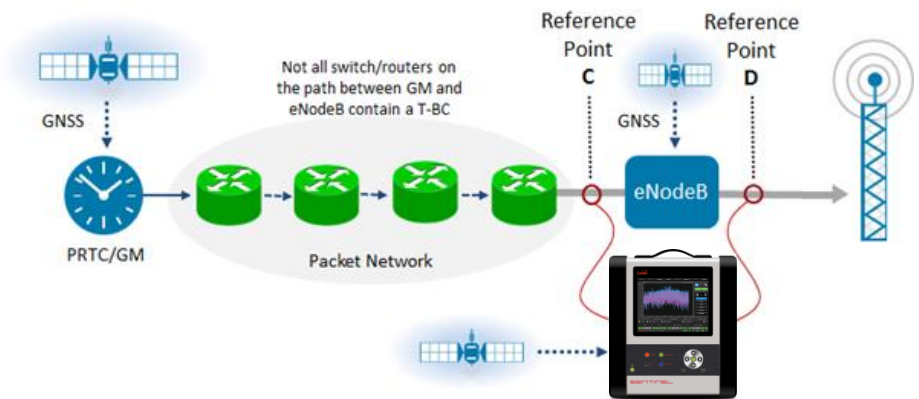

Common interfaces for recovered frequency measurements are E1/T1/2MHz/10MHz. Phase measurement is normally conducted on the 1PPS signal from the eNodeB. The absolute maximum Time Error (TE) should be less than 1350ns with and without GNSS in service. The 2Way TE on the PTP flow is measured at point C and is calculated from the average of a selection of 0.25% of the fastest forward and reverse PTP packets within a 200 second window. The peak to peak value of the pktSelected2WayTE should be less than 1100ns. Sentinel can display the 1PPS TE results at the time of the test, however the PTP 2Way TE results require further analysis using the Calnex Analysis tool (CAT).

### 2.2 ITU-T G.8271.2 Partial Timing Support

In this case an edge GM is connected to the eNodeB through a packet network that contains elements that are not PTP aware. There is no local GNSS reference. An example of this could be a small cell located on an office LAN. All timing information is sent via PTP from the Edge GM. The same selection criteria is used for the pktSelected2WayTE metric, however, the absolute magnitude of the pktSelected2wayTE should be less than 1100ns.

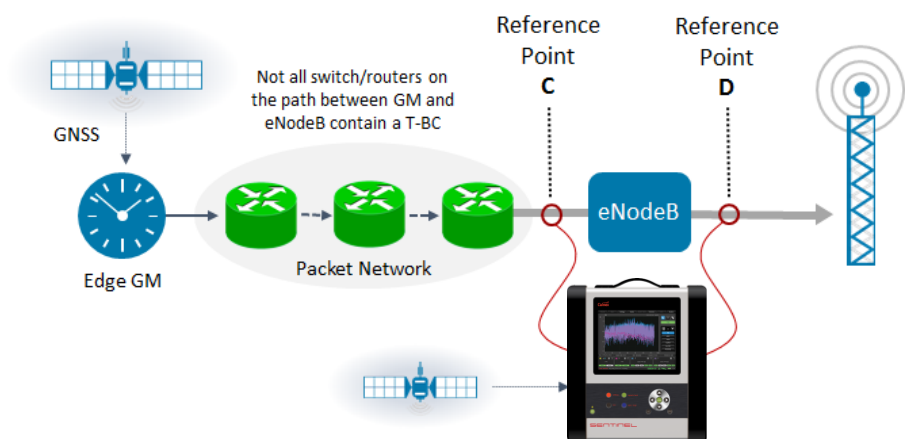

Note these limits are based on G.8271.2 Type I networks. At the current time Type II networks are for further study.

### 3 Sentinel Configuration

Before performing any measurements, follow the steps below to configure the Sentinel.

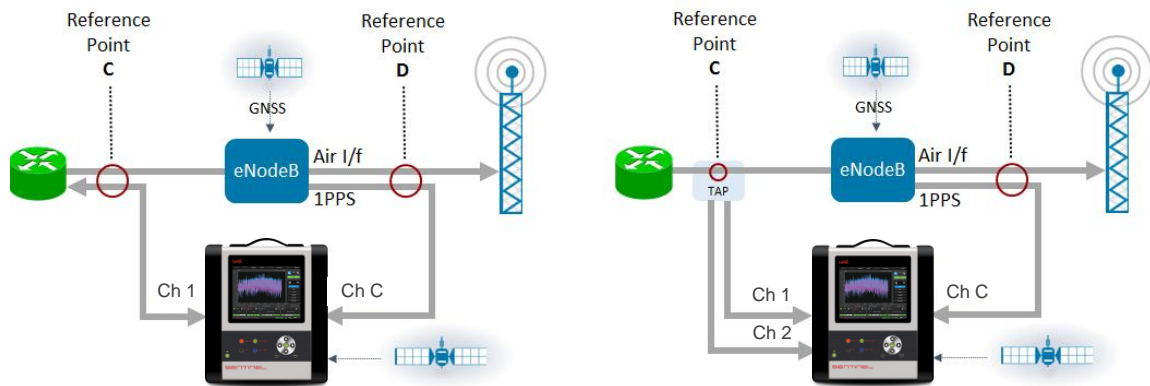

#### 3.1 1PPS Output

Connect the 1PPS Out output on Sentinel to Channel C.

#### 3.2 PTP Connections

If Sentinel is operating as a Pseudo Slave, the Ethernet interface of Channel 1 should be connected to the appropriate port of the switch/router. If Sentinel is operating in Monitor Mode, two PTP ports are required and the Ethernet interface of Channel 1 and 2 should be connected to each analysis port of the splitter or TAP. It does not matter which PTP port is connected to which analysis port.

#### 3.3 Configuring Sentinel Operating Mode

This test requires one Sentinel clock channel and either a single PTP channel running as a Pseudo Slave or two PTP channels running in PTP Monitor mode. Sentinel is configured for these tests from the Mode tab on the main screen.

Select the appropriate clock channel (in this case Channel C) and for PTP either select SyncE / PTP Slave for the appropriate PTP channel (in this case Channel 1) or PTP Monitor Mode. Press the **OK** button.

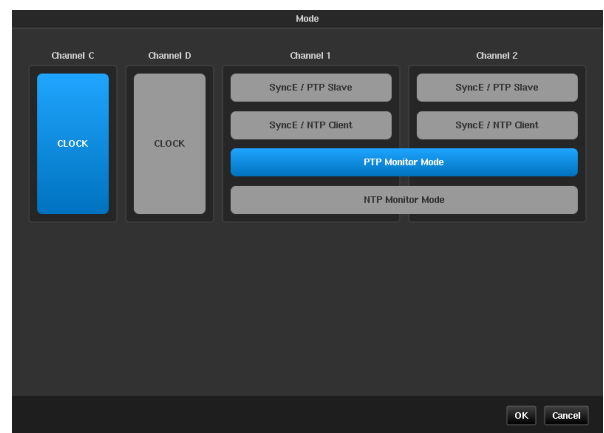
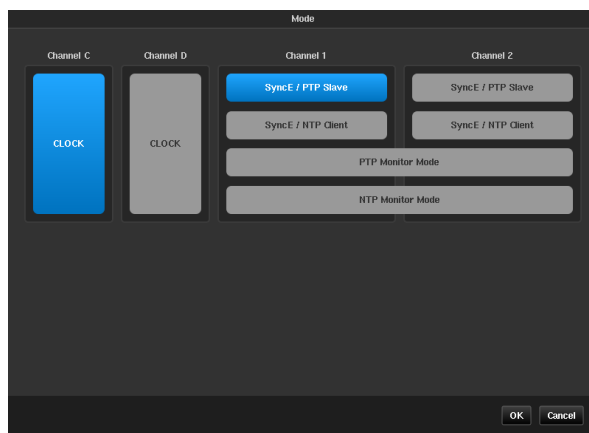

### 3.4 Time Base Settings

From the **Measurement** tab on the **Settings** page, set Sentinel to use the internal clock as time base reference and choose GNSS signal as the internal reference disciplining source. Set the **Measurement Start Behavior** to *Wait till Timebase Reference is ready*, and the **Internal Reference Disciplining Mode** to *Always*.

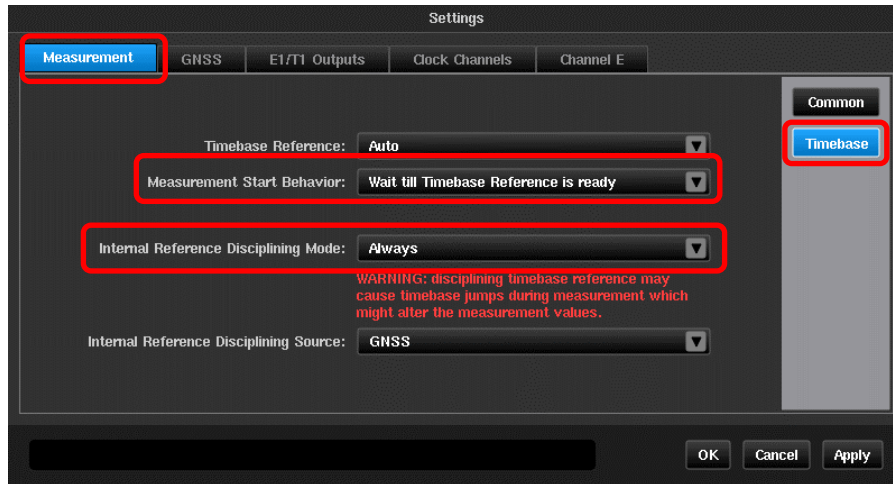

From a cold start, it takes around 15 minutes for the Sentinel internal Rubidium to warm up. With GNSS signal connected, the GNSS receiver needs to lock to at least three satellites before it can output a valid reference to the Rubidium for disciplining. The GNSS receiver will continue to output a valid reference while it is locked to at least three satellites.

If there is no GNSS signal available at the test site, Sentinel's internal Rubidium can be trained in advance and the battery in the Sentinel used to retain the Rubidium phase and frequency information in holdover during transportation from lab to the field. It is recommended to train the Rubidium in the lab for at least 12 hours if training has not been performed in the last week, or 6 hours if training has taken place in the last week.

To put the Sentinel in Transport Mode, from Sentinel front panel, press the  button then click on the **Transport Mode** button.

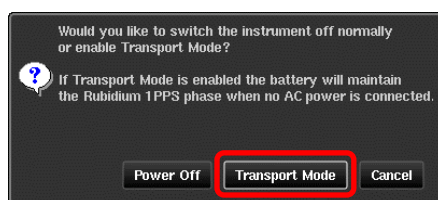

While AC power is applied to Sentinel the Rubidium is powered from this and will automatically switch over to the battery when AC power is removed. It is recommended to limit the time in transport mode to under 3 hours. When AC power is supplied again, the Rubidium will be powered by this and the battery will be re-charged.

### 3.5 Measurement Settings

1. From the **Settings > Measurement > Common** page, select **Mode: TIE + PDV** and **TIE Mode: TIE + 1PPS TE**.
2. Set **Diff TIE reference: 1 PPS Ref**, set **TIE mask: On** and **TIE mask value: 1.35µs**.
3. The recommended test duration is 10000s. However, if intermittent issues occur in the network in a less frequent manner, a longer test duration may be required in order to capture the intermittent issues.

Settings

Measurement GNSS E1/T1 Outputs Clock Channels Channel E

Start: Immediate Start time: 2017-11-17 13:14:45

Mode: TIE + PDV Stop time: 2017-11-17 16:01:25

Duration: 10000 s Sample time: 33 ms

Estimated Data Size: 101.762 MB Auto-Restart: Off

TIE Mode: TIE + 1 PPS TE When measuring TE or Absolute TIE, initial phase offset is not compensated for

Diff TIE reference: 1 PPS Ref

TIE mask: On TIE mask value: 1.35 us

Common Timebase

OK Cancel Apply

### 3.6 PTP Mode

Sentinel can work either in Pseudo-slave Mode, or Monitor Mode. Choose one of the following configuration procedures dependent on the mode Sentinel is operating in.

- **Pseudo-slave Mode:** Sentinel connects to a cell site router.
- **Monitor Mode:** Sentinel connects to a TAP or a splitter.

#### 3.6.1 Pseudo-slave Mode

From the **Settings > Channel 1 > PTP** page select the **G.8275.2 Time/Phase Profile**. This fills the PTP configuration fields with default values relevant to the G8271.2 test. Ensure that the **Master address**, **Domain** and IP version are correct for the GM being tested.

Settings

Measurement GNSS E1/T1 Outputs Clock Channels Channel 1

Profile: G.8275.2 Time/Phase Profile

PTP mode: Unicast Transport protocol: UDP/IPv4

DSCP: 46 Unicast Neg: Enabled

Master address: 192.168.3.11 Ping

Domain: 44

Announce rate: 1 packet/s Sync rate: 64 packets/s

Delay req. rate: 64 packets/s Contract duration: 300

Normalize delays: Off Include Correction Field: Enabled

TE Mask: On TE mask value: 1.1 us

Ethernet Wander Generator SyncE PTP Selection PDV Distribution

OK Cancel Apply

Additionally the Pseudo Slave network related parameters should be set in the **Settings > Channel 1 > Ethernet** page. Ensure that the media type, VLAN, PTP Slave IP address are configured correctly and have been provisioned for the test site.

### 3.6.2 Monitor Mode

If Sentinel is operating in Monitor Mode, then use the **“Discover...”** function on the **Settings > Monitored Channels > Monitor Mode** page to automatically detect the Master/Slave. The system will automatically update the Master/Slave settings per the discovery. Make sure to set up both **Monitored Channels Ethernet** parameters and turn the normalize delays **Off** from the drop down box.



### 3.7 Signal Check

1. Click on the **Health Check** tab on the main screen and select **Signal Check** from the Health Check screen.
2. Make sure signal check detects the 1PPS from the T-TSC and there is an Ethernet link.

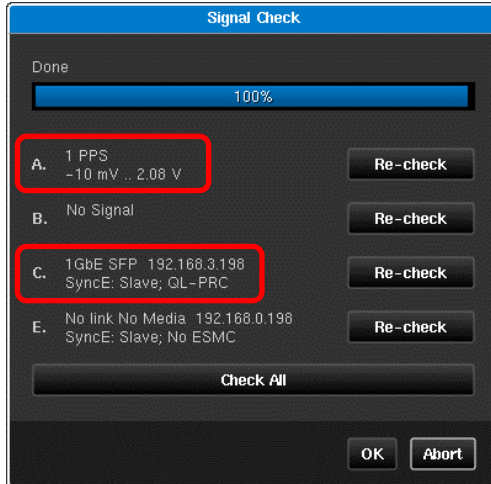

### 3.8 Start the Test

1. Click on the **Start** button.
2. Sentinel will prompt you to select where to store the measurement results. The results can be saved on either Sentinel or on an external USB stick.

**Note:** For long term measurements, it is recommended to use external USB sticks to ensure sufficient storage space.

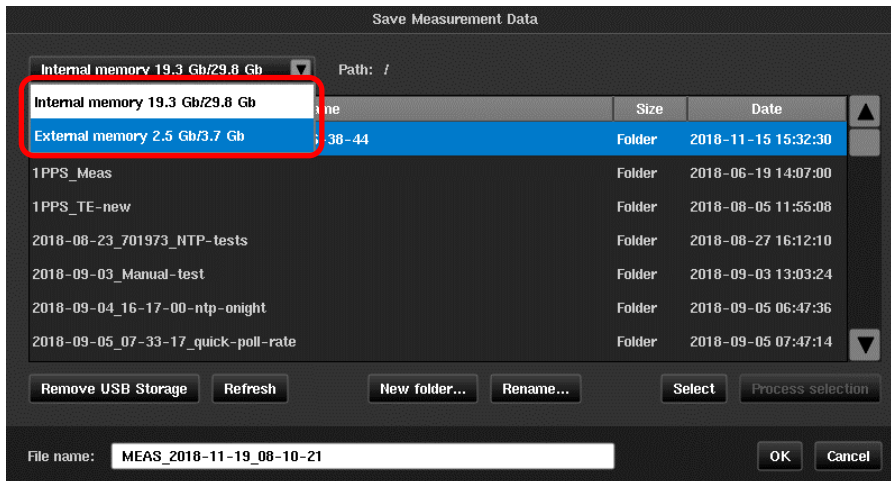

## 4 Measurement Results Display

Once the measurement starts, the graph of the 1PPS time error (TE) with respect to the reference will be displayed on the main GUI window.

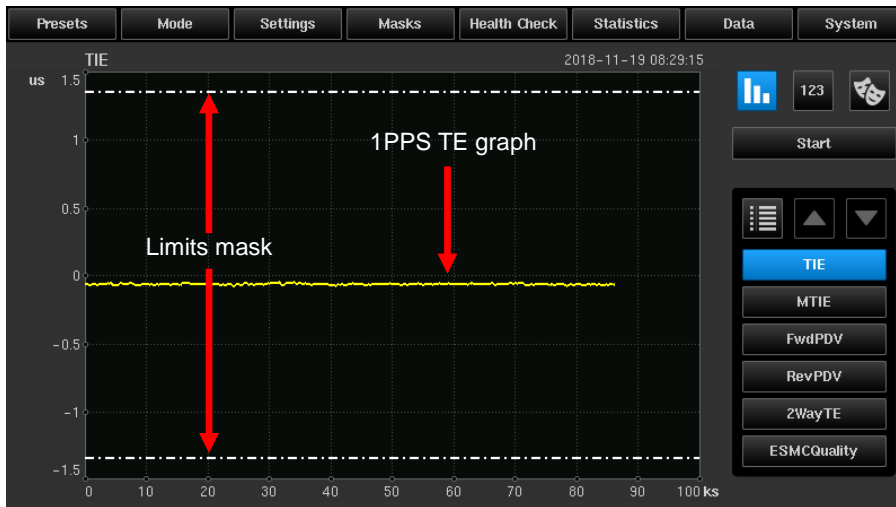

If the PTP GM and the Sentinel emulated Slave establishes the session successfully, the status of the PTP flow is shown in the channel widget.



The full channel status, including the negotiated parameters can be displayed by pressing the  button.

The forward and reverse delays and 2way Time Error are also graphed. To view the forward delay, reverse delay or 2way Time Error, click on the **Fwd PDV**, **Rev PDV** and **2 way TE** buttons.

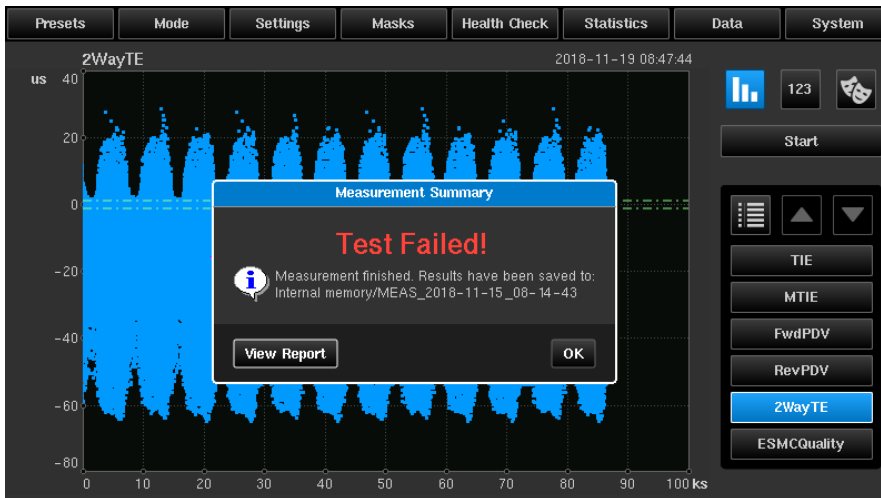

As Sentinel is displaying 2Way TE results for all the PTP messages rather than the pktSelected2WayTE result it is likely that the 2WayTE mask will fail. Further analysis in CAT is required to determine the peak to peak value of pktSelected2WayTE for APTS or the absolute magnitude for PTS. The 1PPS TE result can be read directly from the Sentinel measurement screen or in the measurement.summary.txt file.

## 5 Test Cases

### 5.1 1PPS Time Error Result in CAT

Sentinel stores the 1PPS TE results in the file named **channelA.dset** (assuming that Channel A was connected to the DUT 1PPS output). This file can be loaded through the **Select File > Open File** dialogue box or by dropping the file onto the CAT window. A limit can be configured and CAT will automatically display Pass/Fail against that criteria. Statistics on the Maximum, minimum and mean values of the results are also displayed.

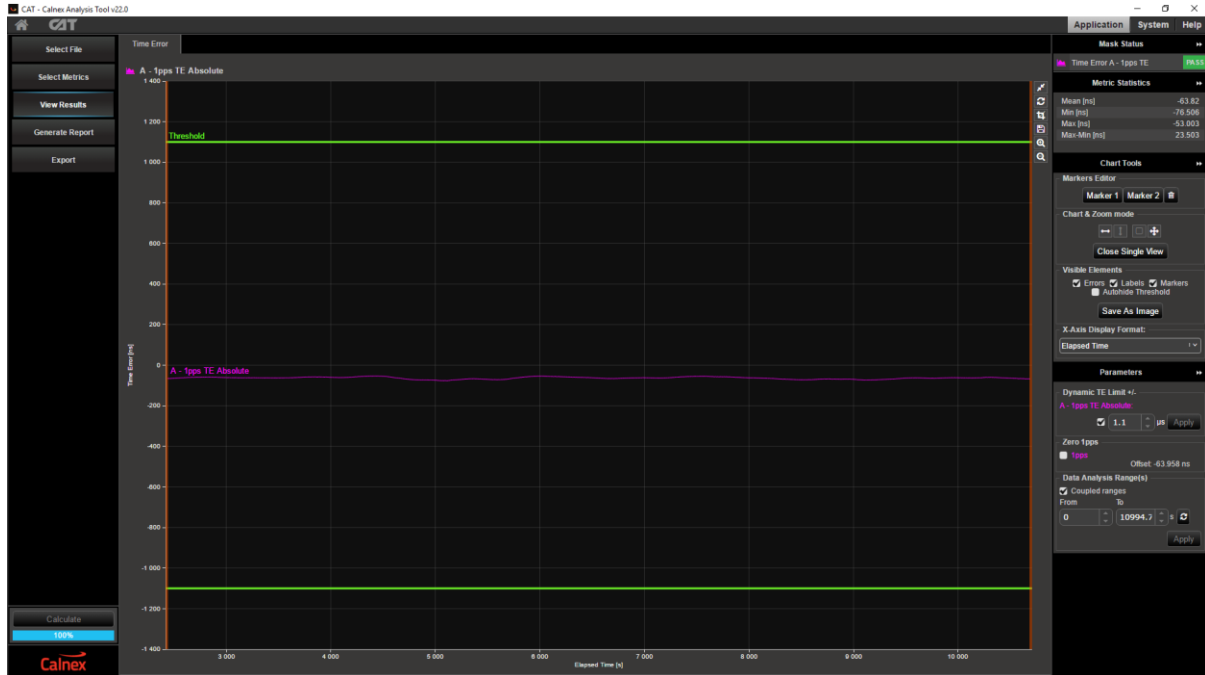

### 5.2 Generating pktSelected2WayTE Results using CAT

To generate the `pktSelected2WayTE` results, the forward and reverse PDV results from Sentinel should be loaded into CAT. In Pseudo Slave mode these files are named **channel1\_FWD\_PDV.dset** and **channel1\_REV\_PDV.dset**. In Monitor Mode the results are always stored in **channel1\_FWD\_PDV.dset** and **channel1\_REV\_PDV.dset**.

Once the files are loaded, maximize the 2 Way Time Error and select the Packet Selection check box. Enter **200** into the Selection Window box and **20** into the Window Step Size. Select **Band Percentage** in the Select Algorithm drop down menu and set the Lower value to **0** and the Upper to **0.25**, then press **Apply**.

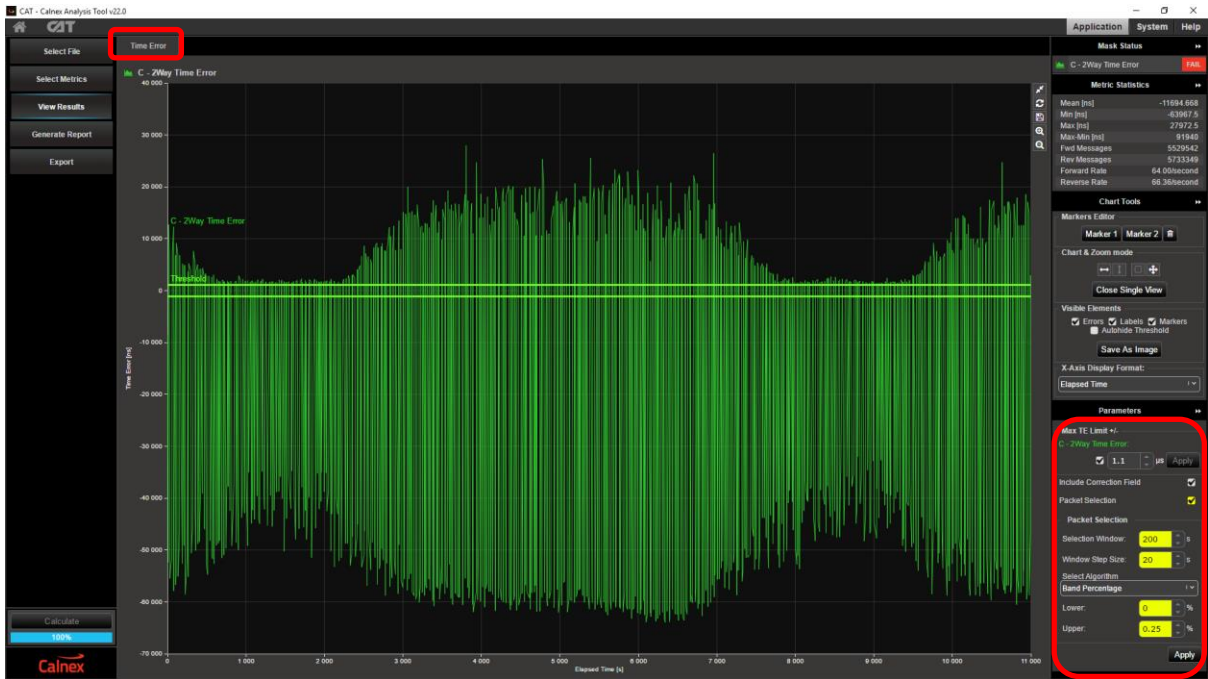

Press the **Calculate** button to display the pktSelected2WayTE results. Again the result can be compared against an absolute limit and the metric results are also displayed.

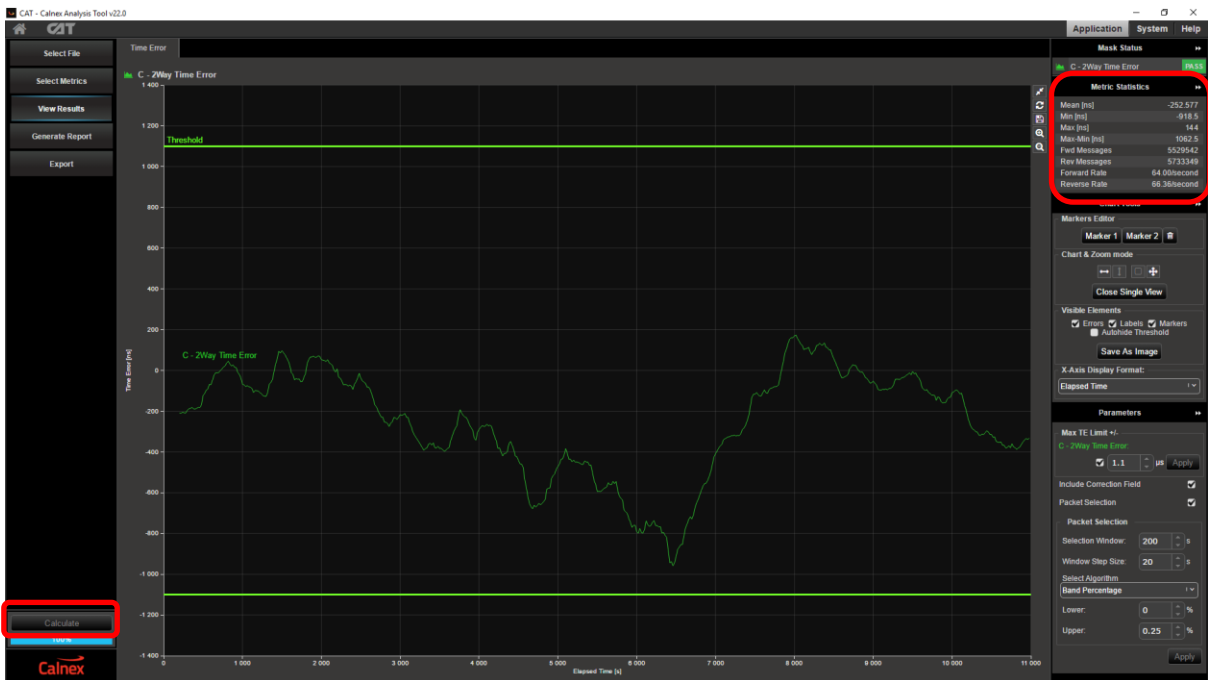

### 5.3 Measurements

#### 5.3.1 APTS Time Error Measurements

For APTS, Time Error measurements should be made on the 1PPS output of the eNodeB (with and without GNSS connected) and the 2Way Time Error should be measured on the PTP flow.

The metrics for APTS are that the 1PPS max |TE| should be less than 1350ns, with and without GNSS and the peak to peak value of the pktSelected2WayTE should be less than 1100ns. Note that the absolute value of

pktSelected2WayTE is not relevant for APTS, only the variation during holdover testing. This means that the result must be retrieved from the CAT maximum and minimum results since the Max TE +/- limits are centered around 0 ns.

As an example the following screenshot shows results for the 1PPS TE measurement and the pktSelected2WayTE for an APTS configuration.



Maximizing the 2Way Time Error graph allows the peak to peak value to be read from the Metric Statistics panel.

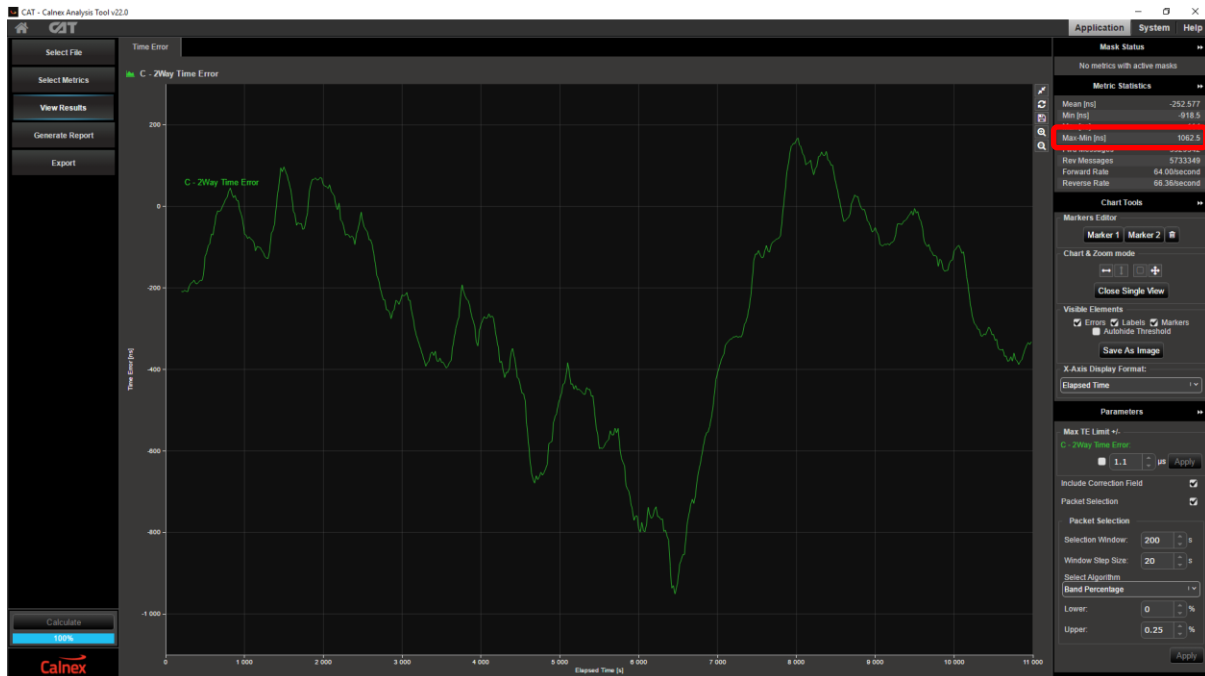

The 1PPS |TE| measurement is 76.506ns, well within the 1.35μs limit while pktSelected2WayTE varies between -918.5ns and 144ns giving a peak to peak value of 1062.5ns which comes close to the 1100ns limit set by G.8271.2 and would require further investigation. The test should be run a second time with no GNSS connected to ensure that the 1PPS TE measurement remains within the 1.35μs limit, while the T-TSC is in holdover.

### 5.3.2 PTS Time Error Measurements

For PTS, Time Error measurements should be made on the 1PPS output of the eNodeB and the 2Way Time Error should be measured on the PTP flow.

The metrics for PTS are that the 1PPS max |TE| should be less than 1350ns and the PTP flow max |pktSelected2WayTE| should be less than 1100ns. Note that the absolute value of pktSelected2WayTE is relevant in the PTS case and the CAT Max TE +/- limits can be set to 1100ns.

As an example the following screenshot shows results for the 1PPS TE measurement and the pktSelected2WayTE for a PTS configuration.

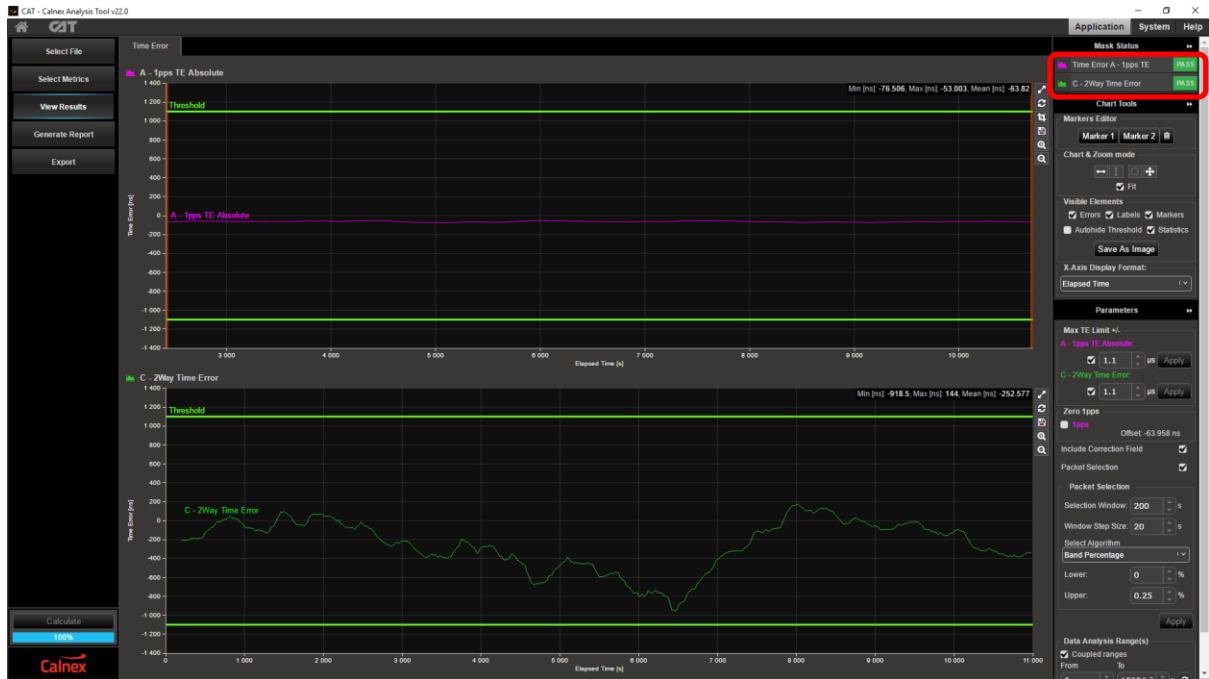

In this case the Max TE Limit +/- field can be set to 1.1 μs to give an automatic Pass/Fail indication. Using the same data the Max | pktSelected2WayTE | in this case is 918.5ns.

### 5.3.3 Sample APTS pktSelected2WayTE Test Results

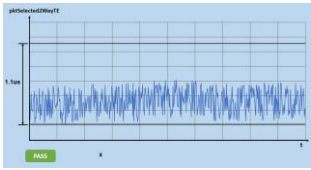
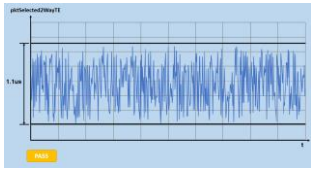
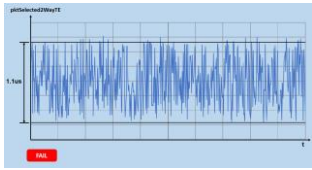
<b>Example Results</b>			
	Peak to peak value within limits - Pass	Peak to peak value close to limits	Peak to peak value outside limits - Fail
<b>Possible Causes</b>	n/a	n/a	<ul style="list-style-type: none"> <li>• Network congestion</li> <li>• Network too large</li> <li>• Equipment TE</li> </ul>
<b>Possible Impact</b>	n/a	n/a	<ul style="list-style-type: none"> <li>• Dropped calls</li> <li>• Slow data transfer</li> </ul>
<b>Next Action</b>	n/a	<ul style="list-style-type: none"> <li>• Network is under stress</li> <li>• Need to closely monitor the network for traffic growth</li> </ul>	<ul style="list-style-type: none"> <li>• Measure TE step by step</li> <li>• Locate where asymmetry comes from</li> <li>• Compensate by adding a fixed delay on the switch(s) and router(s)</li> <li>• Reconfigure network with fewer intermediate nodes</li> </ul>

### 5.3.4 Sample APTS 1PPS max|TE| Test Results

GNSS Connected	pktSelected2WayTE peak to peak	1PPS max TE	Action
Yes	n/a	<1.35µs	n/a
Yes	n/a	>1.35µs	Verify GNSS antenna has a clear view of the sky and that the quality of the signal the GNSS module is receiving is adequate
No	n/a	<1.35µs	n/a
No	Fail	n/a	Resolve issues as in pktSelected2WayTE table
No	Pass	>1.35µs	Adjust / improve T-TSC frequency recovery algorithm

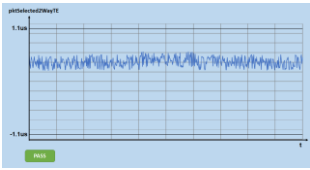
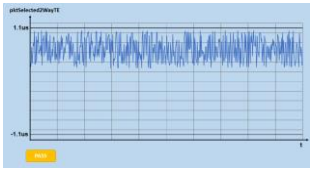
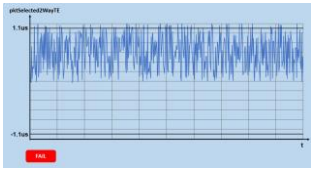

### 5.3.5 Sample PTS pktSelected2WayTE Test Results

<b>Example Results</b>			
	Max  pktSelected2WayTE  within limits - Pass	Max  pktSelected2WayTE  close to limits	Max  pktSelected2WayTE  outside limits - Fail
<b>Possible Causes</b>	n/a	n/a	<ul style="list-style-type: none"> <li>• Network congestion</li> <li>• Network asymmetry</li> <li>• Network too large</li> <li>• Equipment TE</li> </ul>
<b>Possible Impact</b>	n/a	n/a	<ul style="list-style-type: none"> <li>• Dropped calls</li> <li>• Slow data transfer</li> </ul>
<b>Next Action</b>	n/a	<ul style="list-style-type: none"> <li>• Network is under stress</li> <li>• Need to closely monitor the network for traffic growth</li> </ul>	<ul style="list-style-type: none"> <li>• Measure TE step by step</li> <li>• Locate where asymmetry comes from</li> <li>• Compensate by adding a fixed delay on the switch(s) and router(s)</li> <li>• Reconfigure network with fewer intermediate nodes</li> </ul>

### 5.3.6 Sample PTS 1PPS max|TE| Test Results

Max  pktSelected2WayTE	1PPS max TE	Action
n/a	<1.35µs	n/a
Fail	n/a	Resolve issues as in pktSelected2WayTE table
Pass	>1.35µs	Adjust / improve T-TSC time / phase recovery algorithm

 **Note:** This test plan examined synchronization test of TDD-LTE networks using PTP technology. Please refer to other test documents from Calnex for frequency synchronization using NTP<sup>2</sup> and frequency synchronization using PTP<sup>2</sup>.

<sup>2</sup> Calnex document number CX5017

<sup>2</sup> Calnex document number CX5018

## Appendix A: PTP Synchronization Technology

IEEE1588v2 (also known as Precision Time Protocol, PTP) is an industry-standard protocol that enables the precise transfer of frequency and time to synchronize clocks over packet-based Ethernet networks. It synchronizes the local slave clock on each network device with a system Grandmaster clock and uses traffic time-stamping, with sub-nanoseconds granularity, to deliver the very high accuracies of synchronization needed to ensure the stability of base station frequency and handovers. Timestamps between master and slave devices are sent within specific PTP packets and in its basic form the protocol is administration-free.

Of course, the precision and performance of the PTP protocol is based on the precision of the timestamp. The timestamps of incoming and outgoing packets clearly need to be recorded and assessed to ensure synchronization of master and slave devices. Differences in time and frequency between clocks and subsequent equipment corrections need to be evaluated, while clocks must be measured to ensure they are within their specified limits. Further, delays and drifts in synchronization and their effect on the transfer of timing through the network need to be considered too. Here, we examine the precision of timestamp synchronization, as well as the accuracy of clocks under various network scenarios, before deploying equipment in an operational network.

There are two types of message in the PTP protocol: Event Messages and General Messages. Event Messages are timed messages whereby an accurate timestamp is generated both at transmission and receipt of the message. General Messages do not require timestamps but may contain timestamps for their associated event message.

Events Messages include Sync, Follow-up, Delay-Request and Delay-Response. The PTP work flow is shown below.

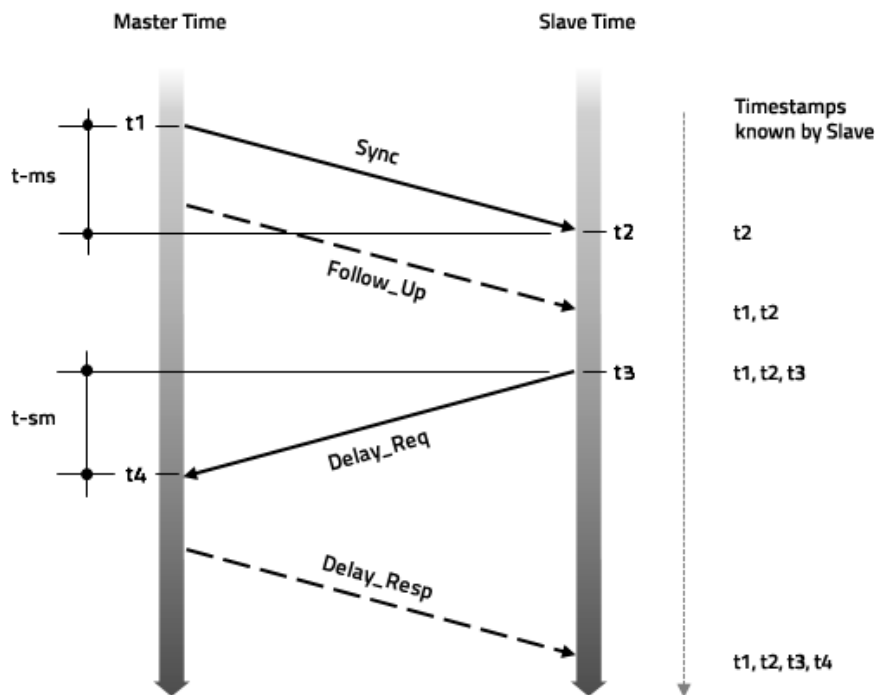

Once the Slave knows the timing of t1, t2, t3, and t4, it can calculate the mean propagation delay ( $T_{mpd}$ ) of the message path and slave clock offset. This can be calculated by:

- $T_{mpd} = ((t2 - t1) + (t4 - t3)) / 2$
- $Offset = t2 - t1 - T_{mpd}$

## Appendix B: ITU-T G.8271.2 Network Reference Model and Limits

Reference points are used on time synchronized packet networks. At each reference point, the network time error limits are defined. The packet network reference model is shown below.

Deployment case 1a

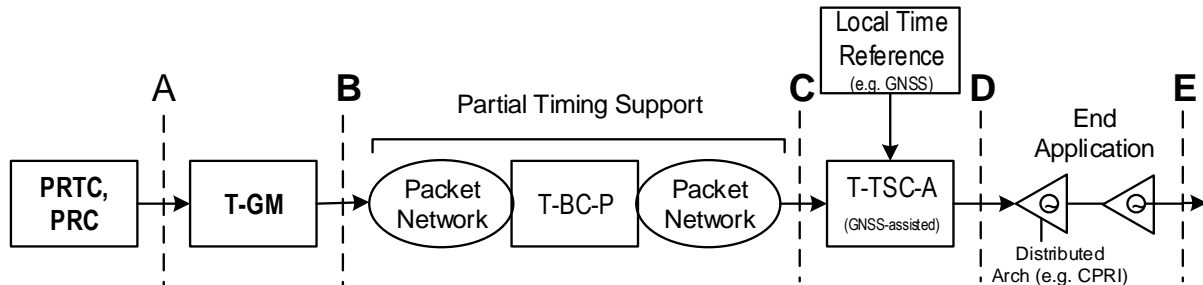

Deployment case 1b

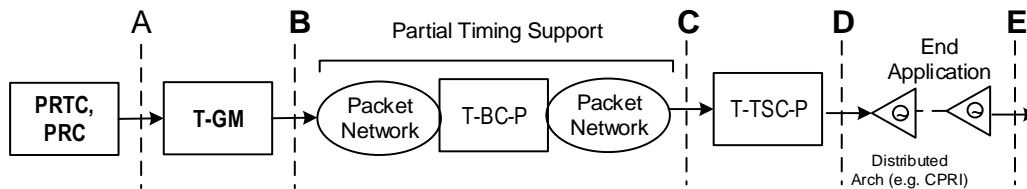

Deployment case 2a

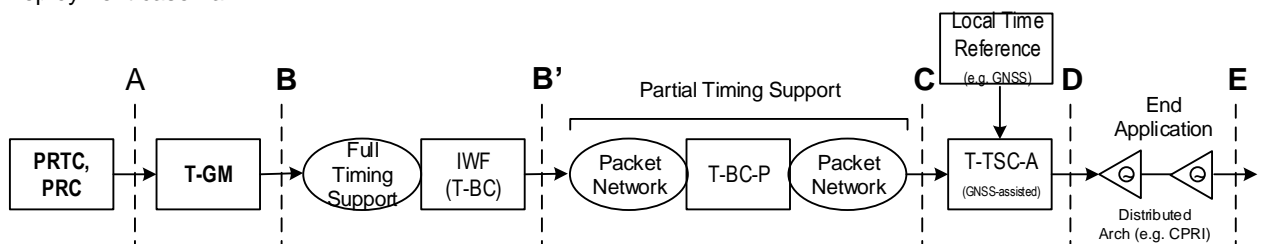

Deployment case 2b

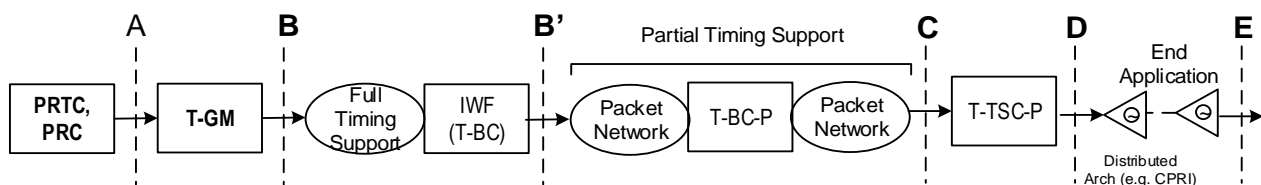

For TDD-LTE applications, the network limits applicable at reference point C and D are expressed in terms of two quantities:

Deployment cases 1a & 2a (APTS)

- Maximum absolute 1PPS time error:  $\max |TE|$
- Peak to peak pktSelected2WayTE

Deployment cases 1b & 2b (PTS)

- Maximum absolute 1PPS time error:  $\max |TE|$
- Maximum absolute pktSelected2WayTE:  $\max |pktSelected2WayTE|$



Calnex Solutions Ltd  
Oracle Campus  
Linlithgow EH49 7LR  
United Kingdom

t: +44 (0) 1506 671 416  
e: [info@calnexsol.com](mailto:info@calnexsol.com)

[calnexsol.com](http://calnexsol.com)

© Calnex Solutions Ltd., Apr 2020  
This document is subject to change without notice.

CX4005 v2.0